

SERVICE MANUAL

TC-800D

STEREO CASSETTE DECK

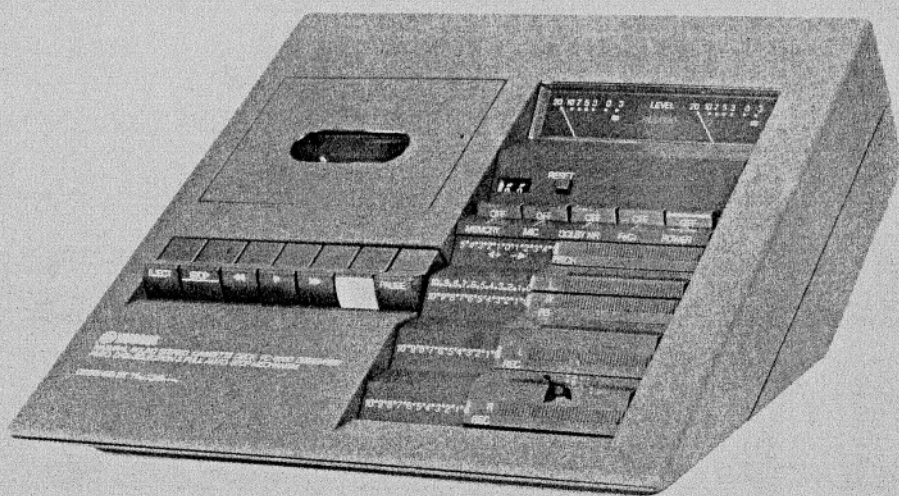

SINCE 1887



YAMAHA

NIPPON GAKKI CO., LTD. HAMAMATSU, JAPAN

ASM-43

① 19



Printed in Japan 7

CONTENTS

SPECIFICATIONS	1
COMPONENTS LOCATION	2
DISASSEMBLY PROCEDURES	4
MECHANICAL CHECKS AND ADJUSTMENTS	6
ELECTRICAL CHECKS AND ADJUSTMENTS	7
PRINTED CIRCUIT BOARD	13
SCHEMATIC DIAGRAM	15
BLOCK DIAGRAM	16
PARTS LIST	17
LINE VOLTAGE CONVERSION	

SPECIFICATIONS

Recording System	4-track, 2-channel stereo	Playback Pitch Control	+3%
Tape Speed	4.8cm/sec (1-7/8 ips)	Fast Wind, Rewind Time	Within 80 seconds (C-60 Tape)
Wow & Flutter	Less than 0.06% (WRMS) Less than 0.2% DIN	Semiconductors	29 Transistors, 4 ICs, 25 Diodes
Signal-to-Noise Ratio	Better than 50dB (DIN, 0dB) Better than 58dB (Dolby ON)	Power Consumption	16W
Total Distortion	Less than 1.5% (1KHz, 0VU)	Power Source	Canada: 117V, 60Hz Europe: 220/240V, 50Hz Other Areas: 117/220/240V, 50/60Hz
Frequency Response	30~13,000Hz (LH Tape) 30~15,000Hz (CrO Tape)	Dimensions (W x H x D)	312 x 98 x 312 mm (12¼" x 3¾" x 12¼")
Bias Frequency	85KHz	Weight	4.8 kg
Input Sensitivity/Impedance	Line: 50mV/100K Ω Mic: 0.5mV/5K Ω (DIN: 0.5mV/5K Ω)	Specifications subject to change without notice.	
Channel Separation	Better than 30dB		
Output Level/Impedance	Line: 0.4V (0VU) Headphone: 3mW/8 Ω , 10mW/150 Ω (0VU)		

COMPONENTS LOCATION

1. FRONT PANEL

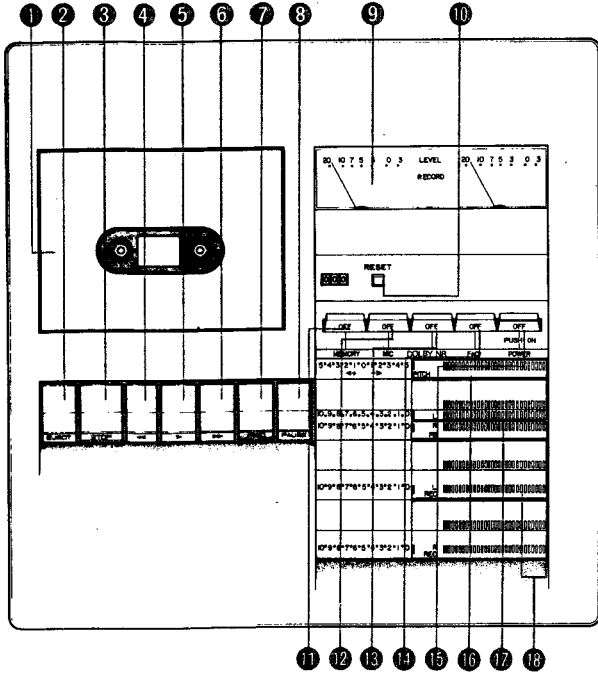

- ① CASSETE BOX
- ② EJECT BUTTON (EJECT)
- ③ STOP BUTTON (STOP)
- ④ REWIND BUTTON (◀◀)
- ⑤ PLAY BUTTON (▶)
- ⑥ F.FWD BUTTON (▶▶)
- ⑦ REC BUTTON (REC)
- ⑧ PAUSE BUTTON (PAUSE)
- ⑨ LEVEL METERS (LEVEL)
- ⑩ TAPE COUNTER RESET BUTTON
- ⑪ MEMORY STOP SWITCH (MEMORY)
- ⑫ MICROPHONE SWITCH (MIC)
- ⑬ DOLBY NR SWITCH
- ⑭ TAPE SELECTOR SWITCH (LH/Fe Cr)
- ⑮ POWER SWITCH (POWER)
- ⑯ PITCH CONTROL (PITCH)
- ⑰ PLAYBACK LEVEL CONTROL (PB)
- ⑱ RECORDING LEVEL CONTROL (REC)

2. REAR PANEL

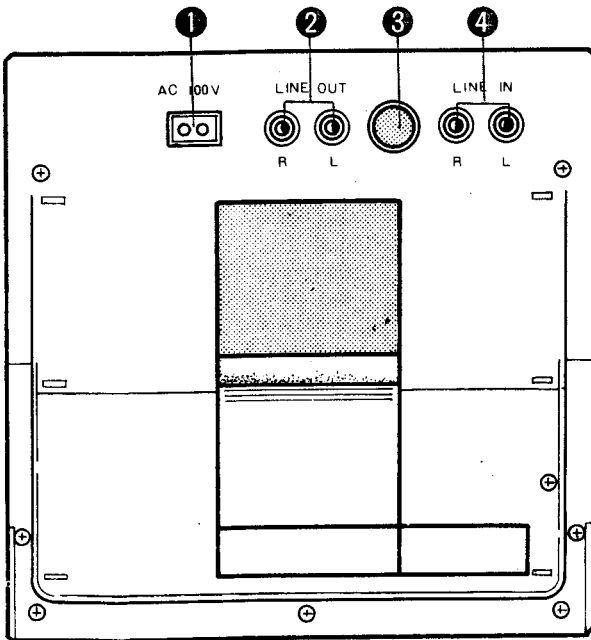

- ① AC INPUT
- ② LINE OUT (LINE OUT)
- ③ DIN CONNECTOR
- ④ LINE IN (LINE IN)

3.TOP VIEW

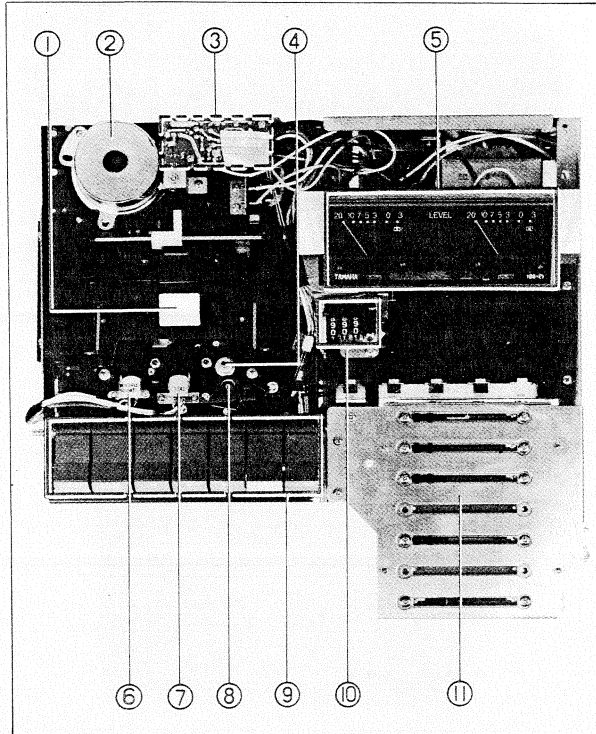

- ① CASSETTE HOLDER
- ② MOTOR
- ③ AUTO SHUT OFF CIRCUIT BOARD
- ④ CAPSTAN
- ⑤ LEVEL METERS
- ⑥ ERASE HEAD
- ⑦ RECORDING/PLAYBACK HEAD
- ⑧ PINCH ROLLER
- ⑨ PUSH BUTTON ASSEMBLY
- ⑩ TAPE COUNTER
- ⑪ FRAME (A)

4.BOTTOM VIEW

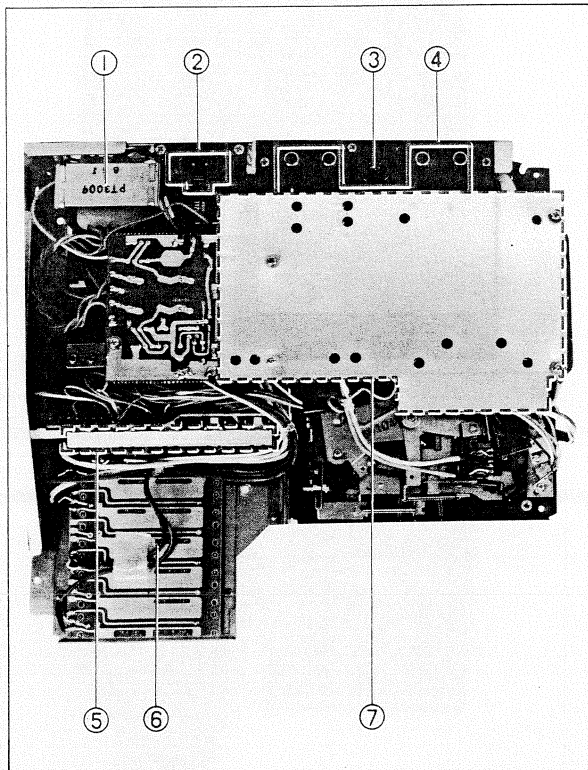

- ① POWER TRANSFORMER
- ② AC SOCKET
- ③ SERVO CIRCUIT BOARD
- ④ PIN JACK PLATE ASS'Y
- ⑤ SWITCH CIRCUIT BOARD
- ⑥ VR CIRCUIT BOARD
- ⑦ RECORDING/PLAY BACK AMP CIRCUIT BOARD

DISASSEMBLY PROCEDURES

CASSETTE COVER REMOVAL

1. Push the Eject button so that the cassette pocket pops up.
2. Push the cassette holder only back down, as shown in PHOTO 1.
3. Push the cassette cover in the direction shown by arrow 1, to release it from its mounting. Then lift out and up as shown by arrow 2 to remove.

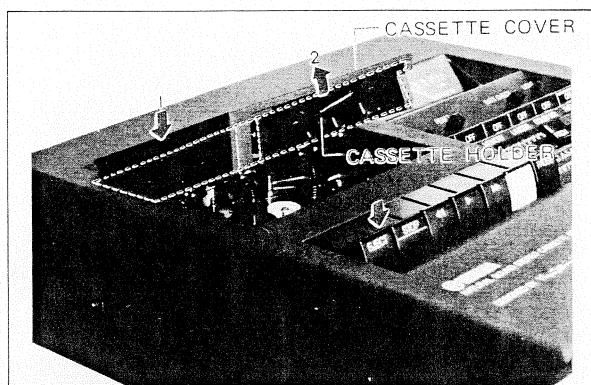

PHOTO 1

BOTTOM CASE REMOVAL

1. Turn the unit upside down and remove screws (1) to (9) shown in PHOTO 2.
2. Gently lift off the case.

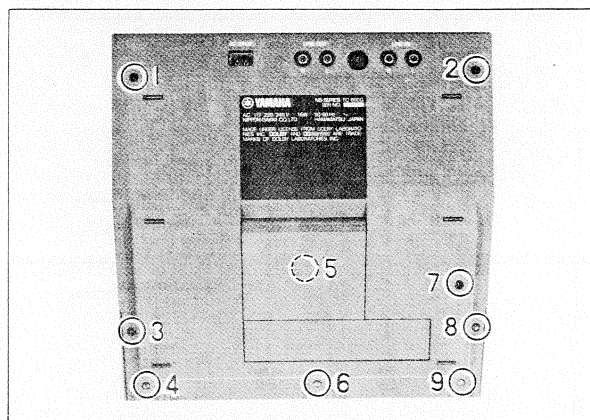

PHOTO 2

TOP CASE REMOVAL

1. Remove the cassette cover and bottom case as explained above.
2. Use a 6 mm box wrench to remove hexagonal struts (1) to (3) shown in PHOTO 3.
3. Gently separate the chassis and case.

NOTE: Be sure to match the control set positions with those of the sliders when reassembling.

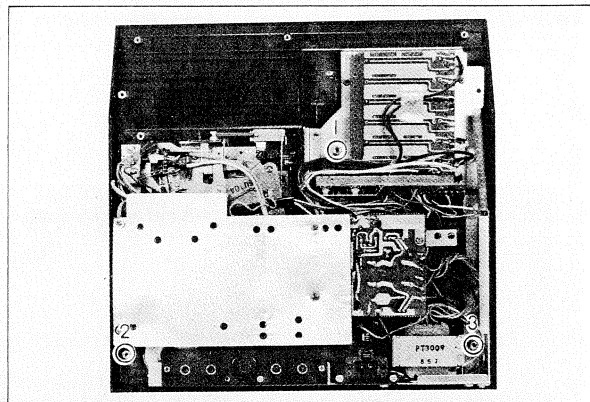

PHOTO 3

TAPE TRANSPORT ASSEMBLY REMOVAL

1. Separate the bottom case, top case and chassis as explained above.
2. Remove screws (1) to (8) shown in PHOTO 4.
3. Separate the tape transport assembly from the chassis. At this time be careful not to use too much force on the leads connected to the tape transport assembly, or on the recording/playback amp board.

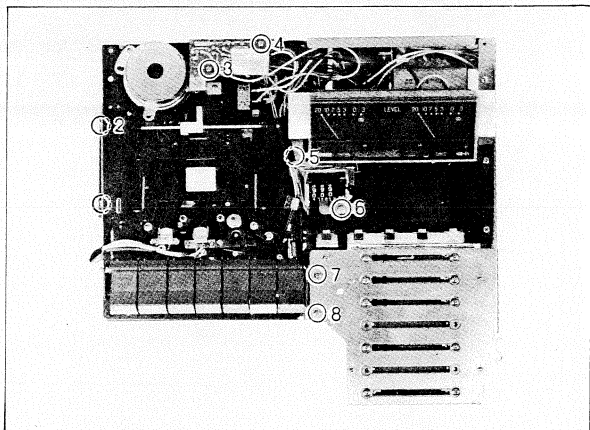

PHOTO 4

CAPSTAN BELT REPLACEMENT

1. Remove the recording/playback amp board.
2. Open lead clamp (1) in Fig. 1 and remove the leads.
3. Remove spring (2).
4. Remove flywheel bearing plate fixing screws (3) to (5).
5. Take off the flywheel bearing plate; now the belt can be replaced.

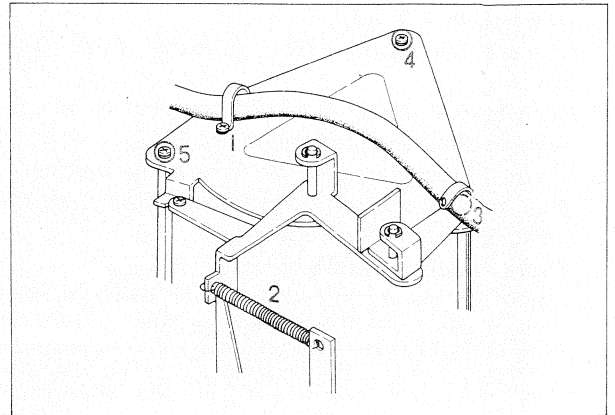

Fig. 1

REMOVAL OF PUSH BUTTON SW BLOCK

1. Remove the frame, according to procedure (2).
2. Remove the REC/PB AMP section.
3. Remove screw (1).
4. Remove spring (A) (PHOTO 5).
5. Remove spring (A) (PHOTO 6).

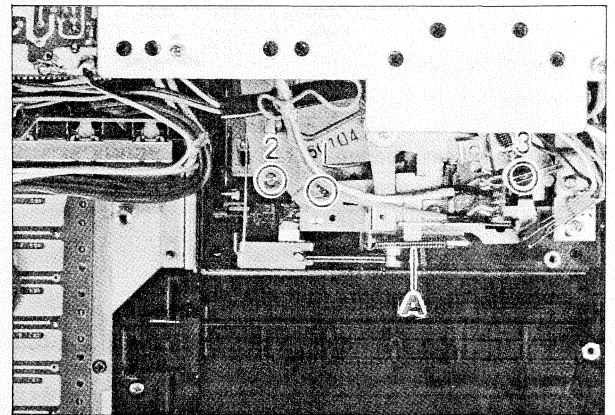

PHOTO 5

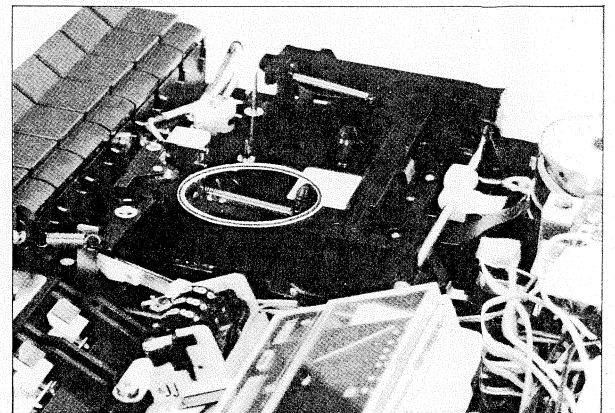

PHOTO 6

MECHANICAL CHECKS AND ADJUSTMENTS

FLUTTER/TAPE SPEED

1. Connect the flutter meter to either LINE OUT jack.
2. Connect the digital frequency counter to the remaining LINE OUT jack. shown in Fig. 2.
3. Set the PITCH control to the center (zero) position.
4. With the PB controls at maximum, play back the TEAC MTT-111 3KHz test tape.
5. Flutter should be 0.06% or less.
6. Adjust VR shown in Fig. 3 for (3,000Hz \pm 20Hz or less) reading on the frequency counter.

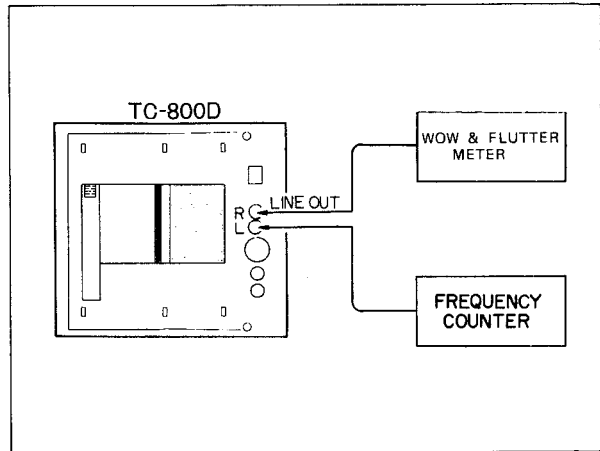

Fig. 2

PITCH CONTROL

7. When the PITCH control is set all the way to the left (+5) and right (-5), the frequency counter should indicate between 3,090 and 3,150Hz at the +5 setting, between 2,850 and 2,910Hz at -5.

FAST WIND TIME

1. Clean all tape path components and check for full AC line voltage.
2. Using a C-60 cassette, the fast wind time (fast forward or rewind) should not exceed 80 seconds.

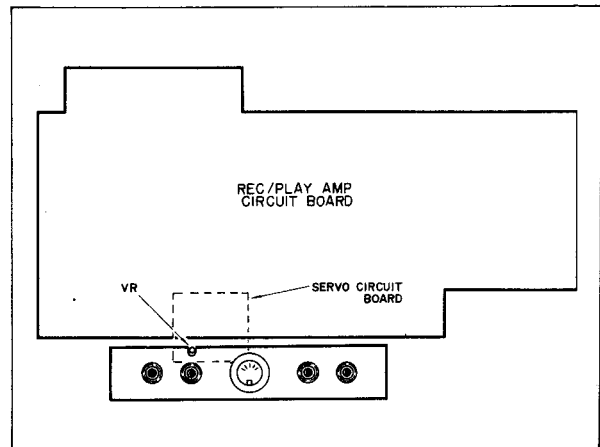
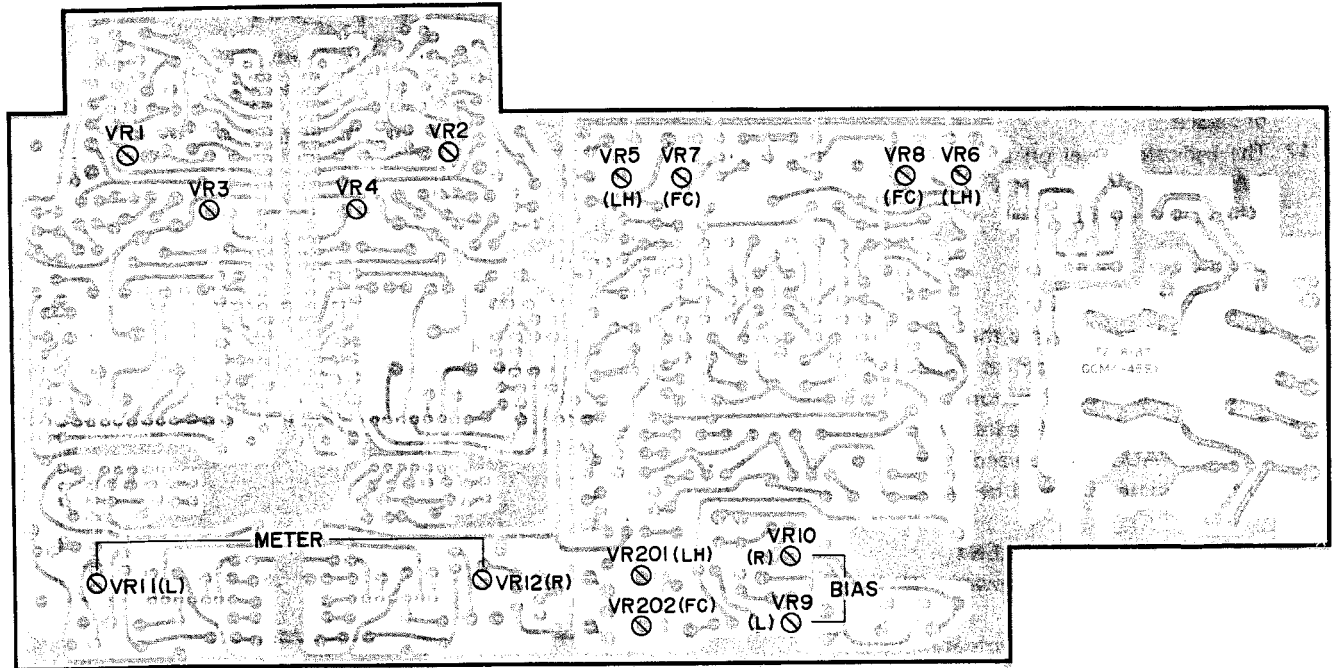

Fig. 3

ELECTRICAL CHECKS AND ADJUSTMENTS

- Before performing any maintenance on this unit, all metal parts which will come into contact with the tape must be cleaned and demagnetized.
- It is important that the unit be set for the proper voltage and frequency for your locality.
- Set the PITCH control to the center position, unless otherwise indicated.
- Chrome cassette used with this unit should incorporate the new extra hole.
- Value of "dBm" in this manual refers to 0dBm= 0.775V, unless otherwise noted.



HEAD AZIMUTH ADJUSTMENT

1. Connect the VTVM to the LINE OUT jacks shown in Fig. 4.
2. Remove the cassette cover from the unit.
3. Load the TEAC MTT-114 test tape on the unit.
4. With the PB controls at maximum, play a test signal of 10KHz.
5. Adjust the azimuth screw shown in Fig. 5 for maximum VTVM reading.
6. Invert the test tape and repeat the above procedure. Readings should also be taken in reverse play. After adjustment lock it in place with insulating paint.

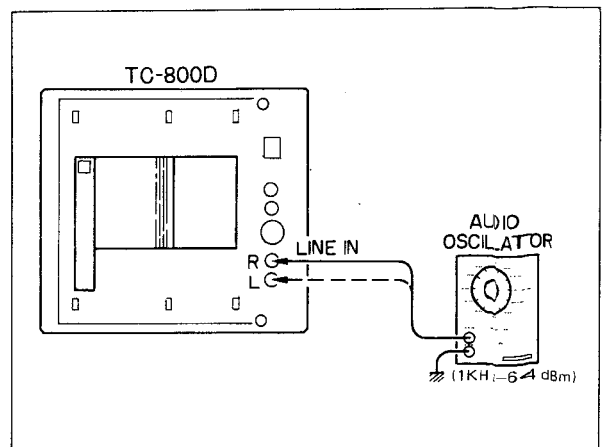

Fig. 4

FREQUENCY RESPONSE

7. Load the TEAC MTT-117L test tape on the unit.
8. With the PB controls at maximum, play test signals of 10KHz, 6.3KHz and 125Hz, 333Hz.
9. The output level of the 10KHz signal should be 1dB higher than that of the other signals. Adjust VR-1/2 shown in Fig. 6 to achieve the specified level.

SPECIFIED OUTPUT LEVEL SET

10. Load the TEAC MTT-112 test tape into the unit.
11. With the PB-controls at maximum, play a test signal of 333Hz.
12. The indicated level on the VTVM should be $-5.5 \pm 1\text{dBm}$ (411mV). Adjust VR-3/4 shown in Fig. 6 to achieve the required level.

NOISE LEVEL CHECK

13. Load an LH cassette into the unit.
14. With the PB controls at maximum, depress the (▶) play and PAUSE buttons.
15. The noise level should be less than -5.5dBm (411mV).
16. Press the PAUSE button and measure the output level. The output level should be below -47dBm (3.5mV).

BIAS VOLTAGE ADJUSTMENT

1. Connect the VTVM between TP-1/2 and ground terminals.
2. Set the REC and PB controls at minimum.
3. Load each type of cassette into the unit.
4. Place the unit in the record mode and depress the PAUSE button.
5. Adjust the VR so that each measuring voltage becomes as indicated below. Proceed with the adjustment following the order of the tape shown in the Table below.

- In case of chrome, a tape with an extra hole would be used.

RECORD LEVEL SET

1. Connect oscillator and valve voltmeter to the MIC input terminal.
2. Connect a volve voltmeter and synchroscope to the LINE OUT terminal.
3. Set the Deck in the recording condition.
4. Set the operating buttons as follow:
 REC VR MAX.
 PB VR..... MAX.
 MIC ON
 REC..... ON

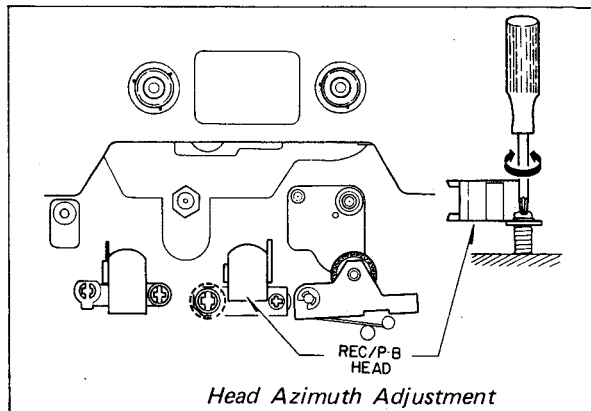

Fig. 5

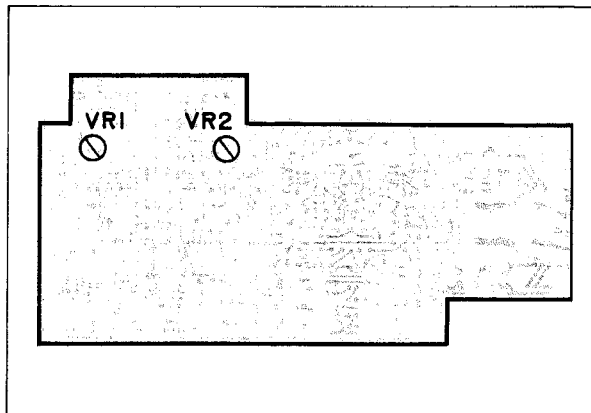

Fig. 6

KIND OF TAPE	TAPE SELECTOR SW	MEASURING ADJUSTING		VOLTAGE
		PART	PART	
L.H	OFF	L side R1~E	VR 9 (L)	4.5mV
		R side R2~E	VR10 (R)	
Fe Cr	ON	L side R1~E	VR202	5.5mV
		R side R2~E		
CrO2	-	L side R1~E	Confirmation	6.5mV
		R side R2~E		

- Set the output of the LINE OUT terminal at 411mV (-5.5 dBm) and make recording by applying 1KHz signal to the MIC input. shown in Fig. 7.
- Playback and adjust the recorded signal so that 411mV (-5.5dBm ± 1dB) is obtained in the output of the LINE OUT terminal.

LH	VR5 (Lch)·VR6 (Rch)
FeCr	VR7 (Lch)·VR8 (Rch)
CrO ₂	Confirmation

	Tape Used
LH	MTT-502
FeCr	
CrO ₂	MTT-505

The adjustment shall be make in the order of LH, Fe-Cr and CrO₂ .

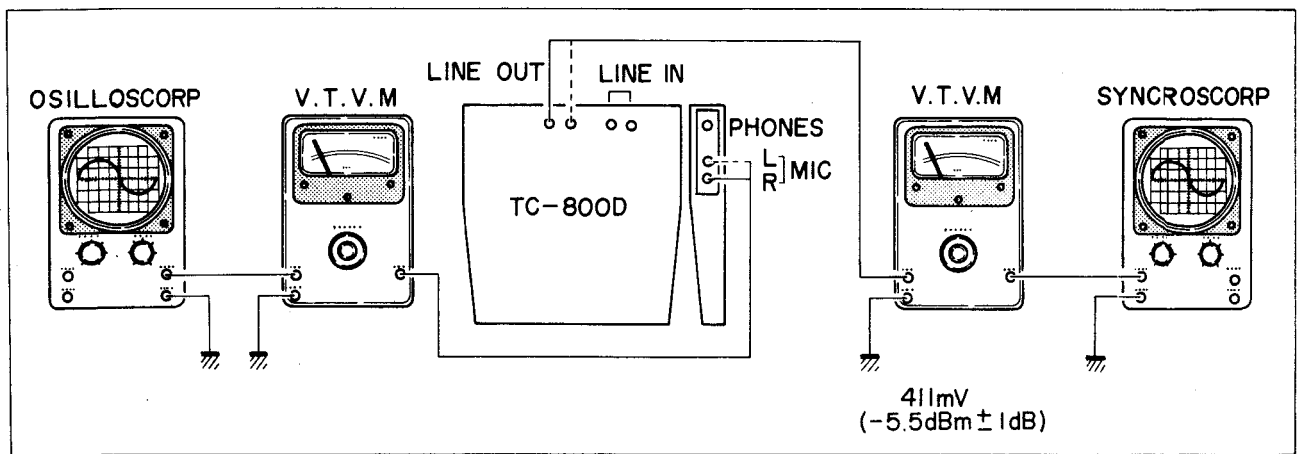

Fig. 7

RECORDING CURRENT ADJUSTMENT

- Shortcircuit the eraser head. shown in Fig. 8.
- Set the Deck in the recording condition.
- Set the operating button and switches as follow:
MIC VR. MAX.
MIC SW. ON
Operating Button REC
- Apply the MIC terminal with 1KHz, -64dBm (0.49 mV) input signal.

KIND OF TAPE	TAPE SELECTOR SW	MEASURING	ADJUSTING	VOLTAGE
		PART	PART	
LH	OFF	(L) R1~E (R) R2~E	VR 5 (L) VR 6 (R)	0.49mV
FeCr	ON	(L) R1~E (R) R2~E	VR 7 (L) VR 8 (R)	0.44mV
CrO ₂	-	(L) R1~E (R) R2~E	Confirmation	0.7mV ± 10%

BIAS LEAKAGE VOLTAGE CHECK

- Connect the VTVM to the LINE OUT jacks.
- Load a blank tape into the unit.
- With the MIC controls at maximum, place the unit in the record mode and depress the PAUSE button.
- The bias leakage voltage should be less than -45.5 dBm (4.1mV).

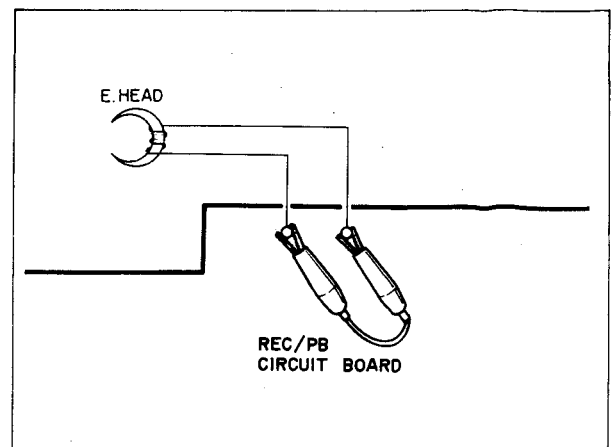

Fig. 8

OVERALL PERFORMANCE

FREQUENCY RESPONSE (DOLBY OFF)

1. Connect an oscillator and valve voltmeter to the MIC terminal.
2. Connect a valve voltmeter and synchroscope to the LINE OUT terminal.
3. Set the REC VR and PB VR at maximum positions.
4. Set the MIC input at 0.049mV (-84dBm), apply signals of 40Hz, 100Hz, 1KHz, 12KHz for LH tape and 30Hz, 100Hz, 1KHz, 14KHz for Fe-Cr, CrO₂ tapes, and record each signal.
5. Playback the recorded signal and check to see if the signal comes in the range shown in Fig. 10 for LH tape and in the range in Fig. 11 for Fe-Cr, CrO₂ tapes.

	Tape Used
LH	MTT-502
FeCr	
CrO ₂	MTT-505

6. When the signal is out of the range:
 - LH tape: Adjust by using the VR9 (Lch) and VR10 (R ch).
 - Fe-Cr tape: Adjust by using the VR 202 (L,R common)
 - CrO₂ tape: There is no adjusting volume.

FREQUENCY RESPONSE (DOLBY ON) ADJUSTMENT

1. Set a measuring instrument and cassette in the same conditions as those of FREQUENCY RESPONSE (DOLBY OFF).
2. Set the MIC input at 0.049mV (-84dBm), apply signals of 30Hz, 100Hz, 1KHz, 10KHz for LH tape and 30Hz, 100Hz, 1KHz, 12KHz for Fe, Cr tapes, and record each signal.
3. Playback the recorded signal and check to see if the signal is in the frequency range shown in Fig.11 for LH tape and in the range shown in Fig.12 for Fe-Cr, CrO₂ tapes.
4. Control volumes to be adjusted are the same as those of FREQUENCY RESPONSE (DOLBY OFF).

	Tape Used
LH	MTT-502
FeCr	
CrO ₂	MTT-505

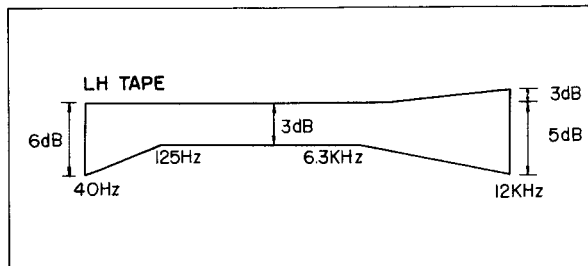

Fig. 9

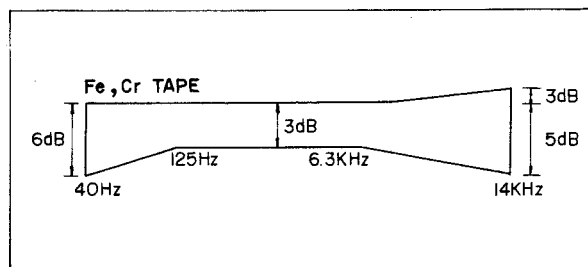

Fig. 10

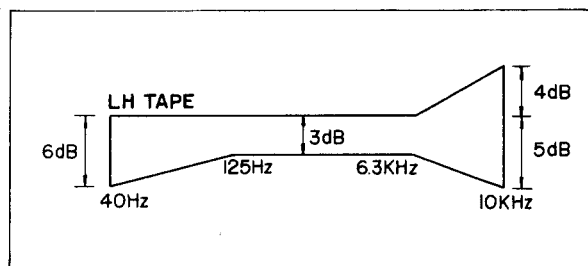

Fig. 11

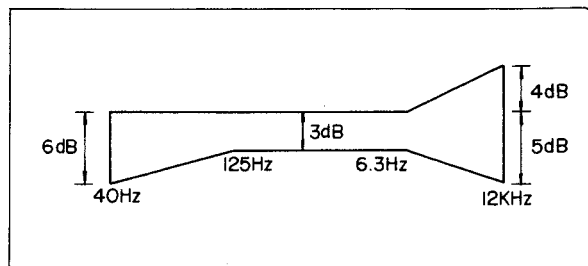

Fig. 12

GENERAL DISTORTION

1. Connect an oscillator and valve voltmeter to the MIC input terminal.
2. Connect a valve voltmeter and strain gauge to the LINE OUT terminal.
3. Set the Deck in the recording condition.
4. Set the operating buttons as follows:
PB VR. MAX.
REC. ON
5. Set the output of the LINE OUT terminal at 411mV (-5.5 dBm) and make recording by applying 1KHz signal to the MIC input.
6. Playback the recorded signal and check to see that the distortion of the output of the LINE OUT terminal will be as indicated in Table below.

Tape Used	Distortion
LH (MTT-502)	2.0% or less
FeCr	2.0% or less
CrO2 (MTT-505)	3.0% or less

GENERAL S/N

1. Connect an oscillator and valve voltmeter to the MIC input terminal.
2. Connect a valve voltmeter and synchroscope to the LINE OUT terminal.
3. Set the Deck in the recording condition.
4. Set the operating buttons as follow:
REC VR MAX.
PB VR. MAX.
REC ON
5. Set the output of the LINE OUT terminal at 411mV (-5.5dBm) and make recording by applying 1KHz signal to the MIC input.
6. Then, record the above recorded signal in the condition with the MIC terminal shortcircuited with 600Ω.
7. Playback the signal recorded in the above 5 and 6 and measure the ratio thereof.

Tape Used	Standards
LH	45dB more than
FeCr	45dB more than
CrO2	45dB more than

- Tape to be used must be completely demagnetized by an eraser.

BRASING RATIO MEASUREMENT

1. Connect oscillator and valve voltmeter to the MIC input terminal.
2. Connect a 1KHz BPF, valve voltmeter and synchroscope to the LINE OUT terminal.
3. Set the operating button as follow:
REC ON
4. Record 1KHz signal with 1.54mV (-54dBm) at the MIC input.
5. Rewind the tape and erase the signal recorded in the above 4 by decreasing voltage (10% decrease) with no signal applied.
6. Playback from the beginning of the tape and measure the ratio of the signal level to the erasing level and check to see that the ratio is more than 60dB.

CROSS-TALK (BETWEEN TRACKS) MEASUREMENT

1. Connect oscillator and valve voltmeter to the MIC input terminal.
 2. Connect a 1KHz BPF, VTVM and synchroscope to the LINE OUT terminal.
 3. Set the operating buttons as follow:
REC VR MAX.
PB VR. MAX.
REC ON
 4. Record 1KHz signal with 0.49mV (-64dBm) at the MIC input.
 5. Playback the signal recorded in the above 4 and read the recording level.
 6. Reverse the cassette and check to see that the ratio of the playback signal level to the level indicated in the above 5 will be more than 50dB.
- Tape to be used shall be completely demagnetized by an eraser.

CHANNEL SEPARATION MEASUREMENT

1. Connect an oscillator and valve voltmeter to the MIC terminal (R).
2. Connect a 1KHz BPF, valve voltmeter and synchroscope to the LINE OUT terminal.
3. Set the Deck in the recording condition.
4. Set the operating buttons as follows:
REC MAX.
PB VR. MAX.
REC ON
5. Record 1KHz signal with 0.49mV (-64dBm) at the MIC input.
6. After recording the input, rewind and playback the tape and check to see if the playback output difference in L and R will be more than 30dB.

METER ADJUSTMENT

1. Connect an oscillator and valve voltmeter to the MIC input terminal.
 2. Set the operating buttons as follows:
REC VR MAX.
PB VR MAX.
REC ON
 3. Set the output of the LINE OUT terminal at 411mV (-5.5dBm) and apply 1KHz signal to the MIC input.
 4. In this condition, adjust the VR11 for L side and VR12 for R side so that the following values are obtained.
Meter indication error: 0VU \pm 2VU
+3VU \pm 1.5VU: At +3dB above 1KHz standard input
-10VU \pm 2VU: At -10dB below 1KHz standard input
- Confirm that the meter needle does not deflect by changing the frequency to 40Hz, 1KHz and 10KHz.

HEADPHONE OUTPUT

1. Connect an oscillator and valve voltmeter to the MIC input terminal.
2. Set the operating buttons as follow:
REC VR MAX.
PB VR MAX.
REC ON
3. Apply 1KHz signal to the MIC input so that the output of the LINE OUT will be 411mV (-5.5dBm), and measure the output of the headphone at this time.
146mV (-14.5dB) \pm 3dB (8 Ω)

AUTO SHUT OFF CIRCUIT BOARD

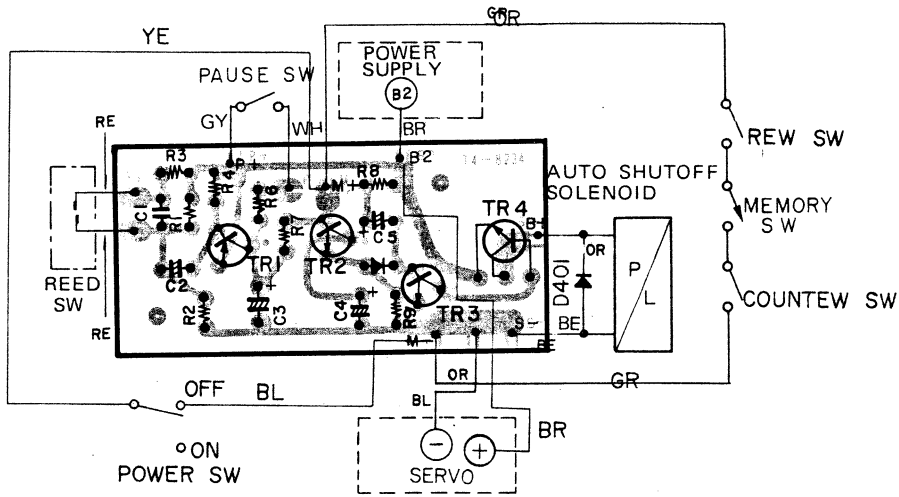

SERVO CIRCUIT BOARD

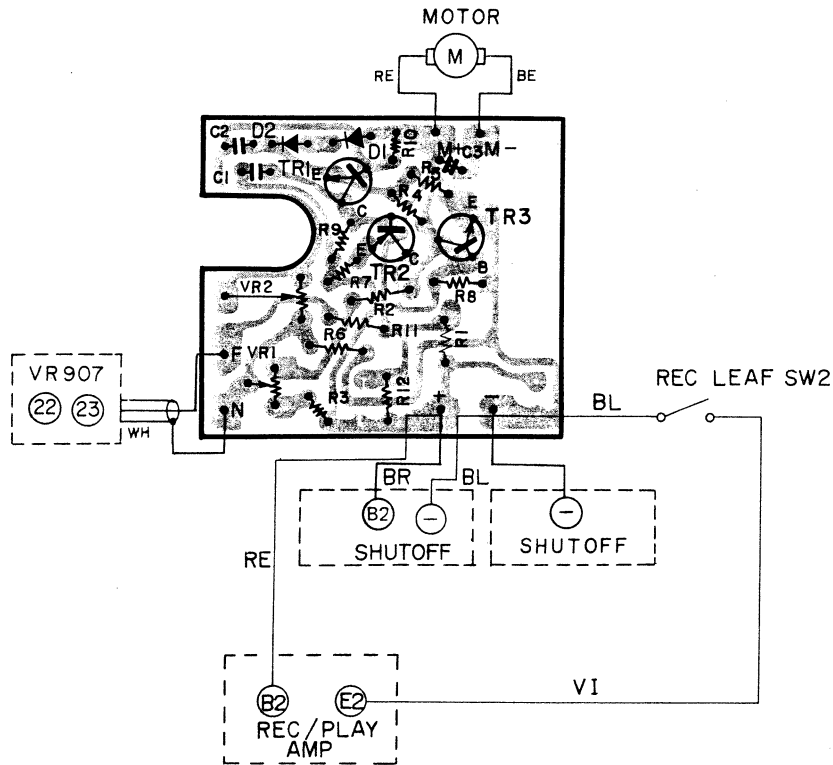

TC-800 SCHEMATIC DIAGRAM

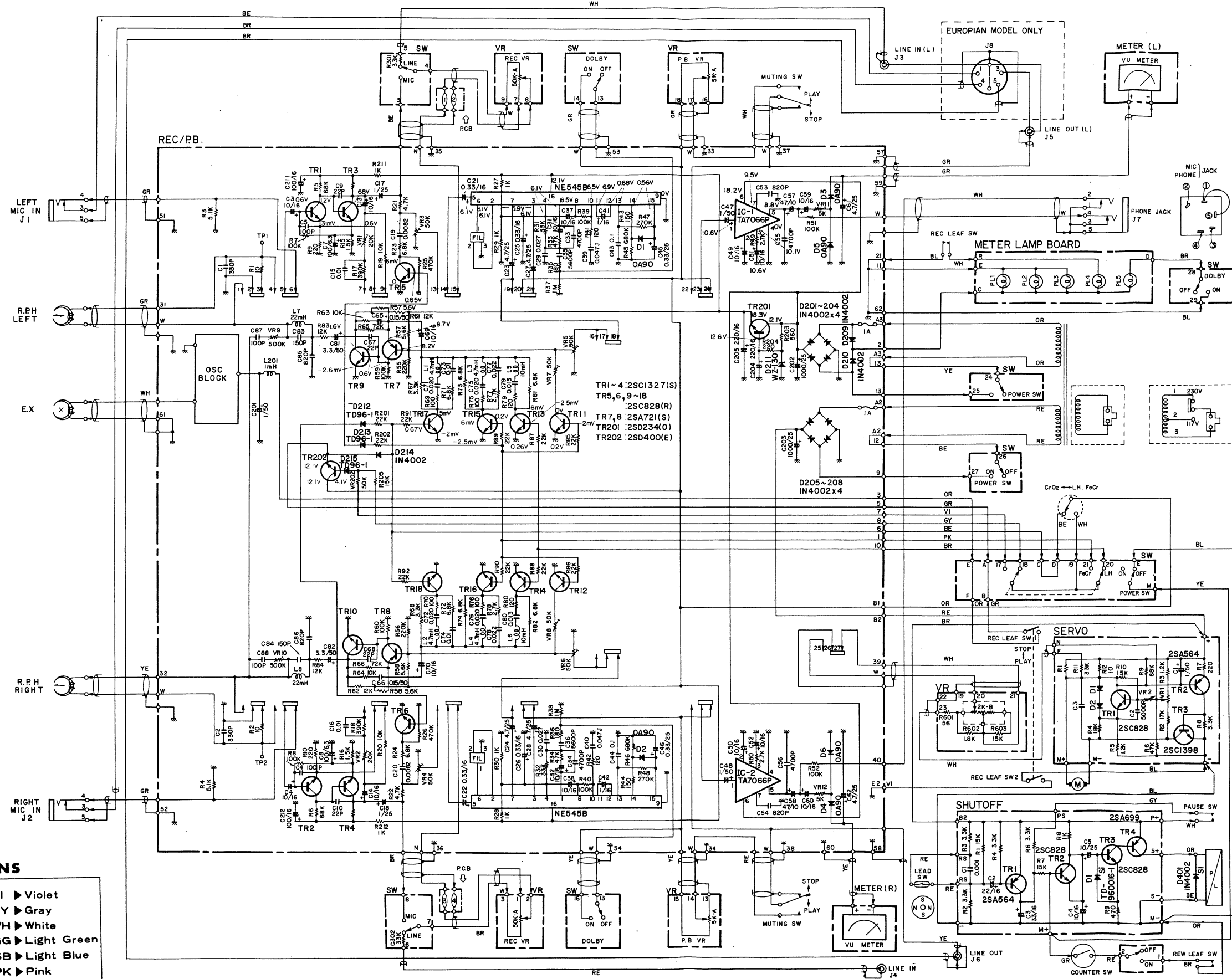

WIRE COLOR ABBREVIATIONS

BL ▶ Black	VI ▶ Violet
BR ▶ Brown	GY ▶ Gray
RE ▶ Red	WH ▶ White
OR ▶ Orange	GG ▶ Light Green
YE ▶ Yellow	SB ▶ Light Blue
GR ▶ Green	PK ▶ Pink
BE ▶ Blue	

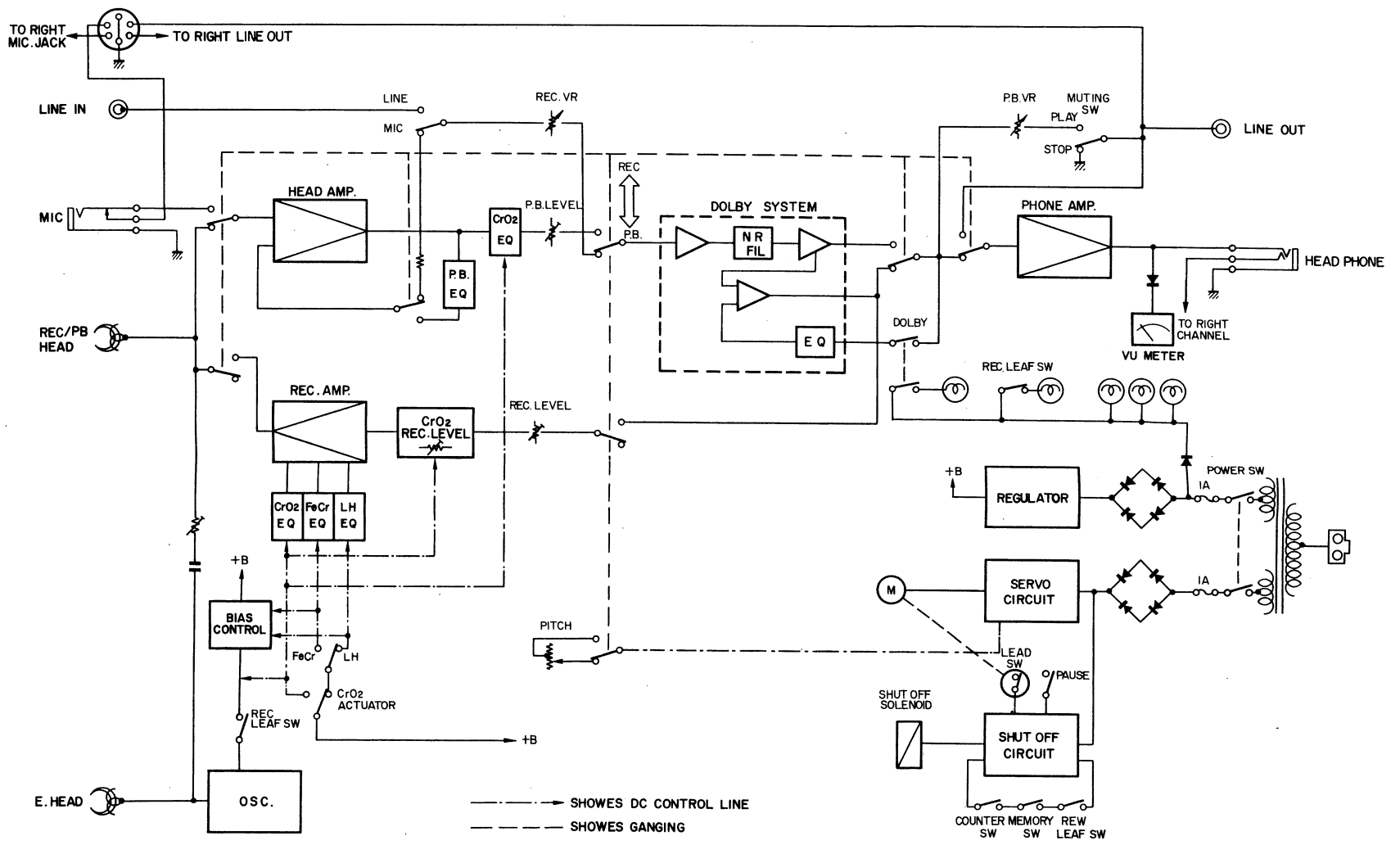

BLOCK DIAGRAM

TRIM PARTS

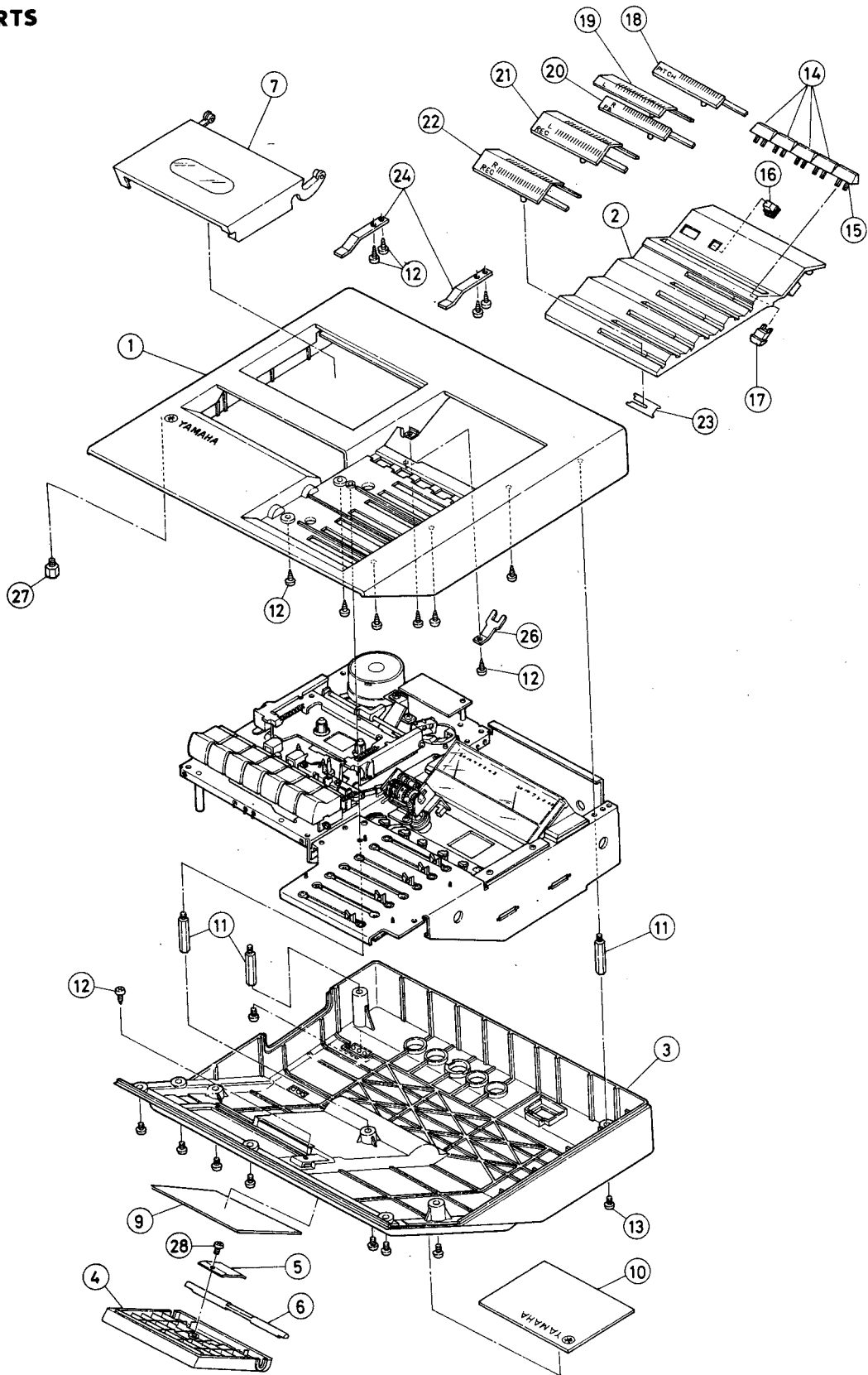

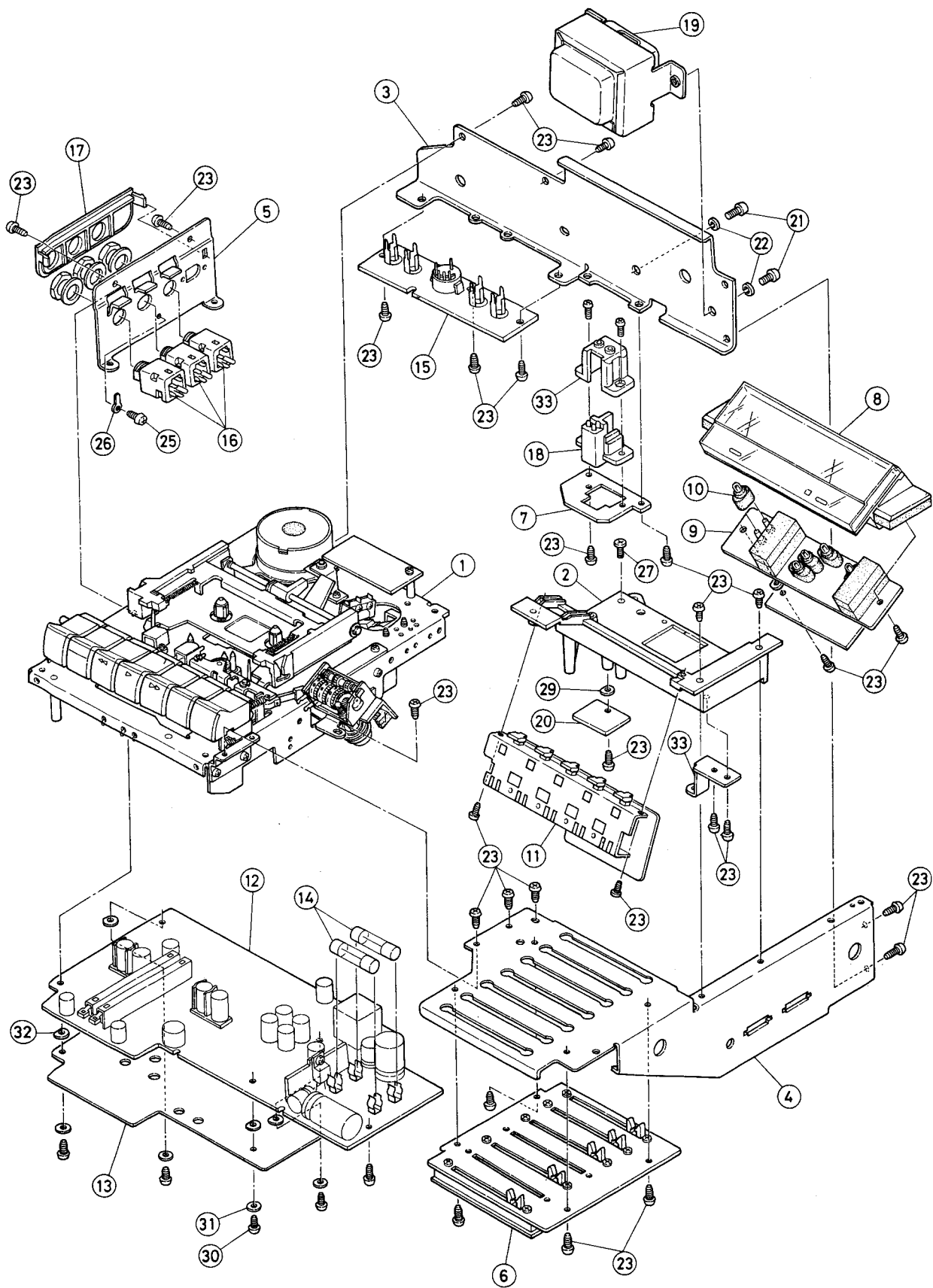

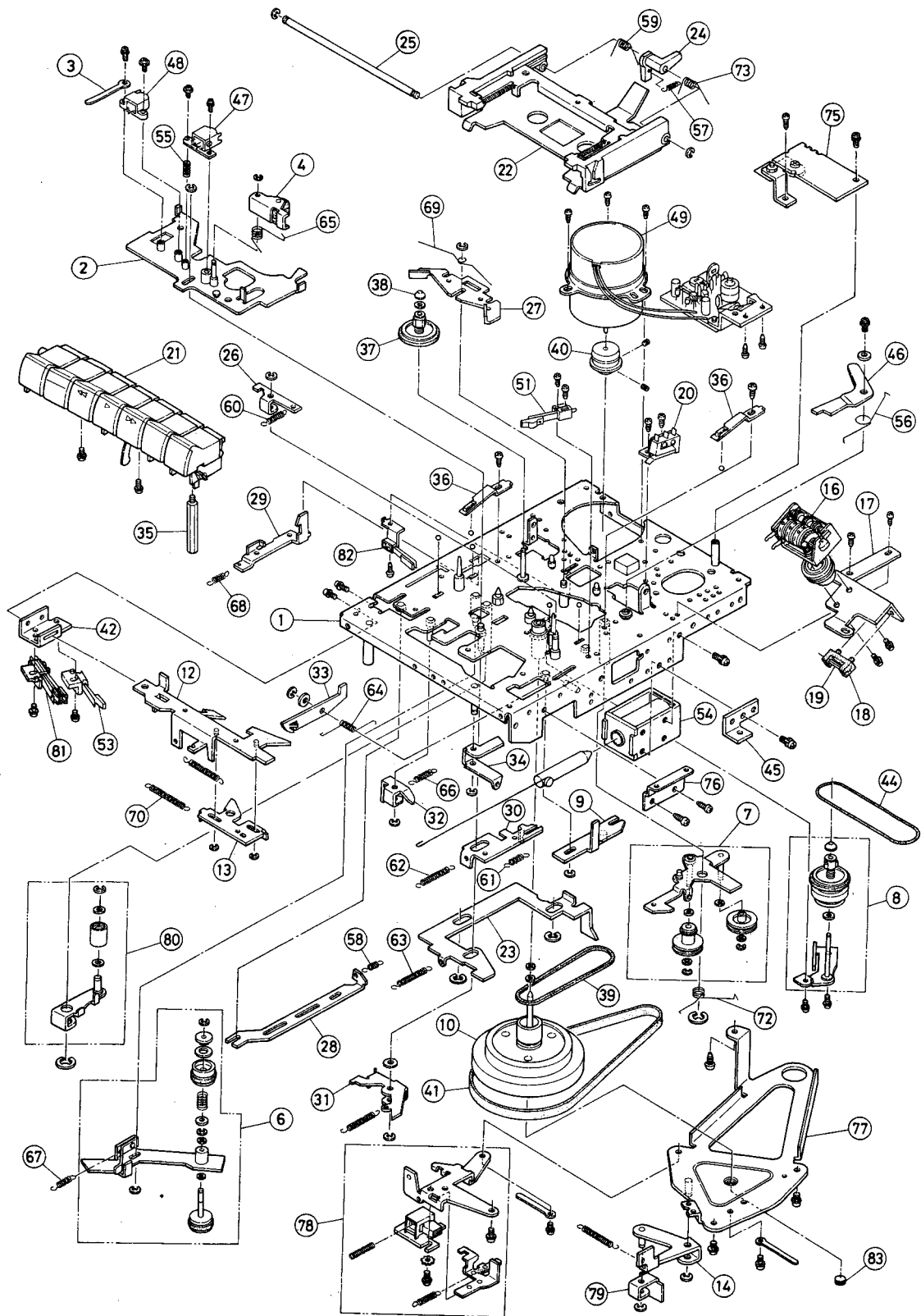

Ref. No.	Part No.	Description	Remarks	Common models
1	42:00:00: SX:99:67:10	Cassette Mechanism Black	メカユニットフレーム	TC-800GL
2	42:00:00: SX:99:56:40	Head Base Ass'y	ヘッドベース組立	TC-800GL
3	42:00:00: SX:99:56:50	Terminal	リード線押え	TC-800GL
4	42:00:00: SX:99:56:60	Rinch Roller Arm Ass'y	ピンチローラーアーム組立 B	TC-800GL
5	42:00:00: SX:99:56:70	Idler B Assembly	アイドラー B 組立	TC-800GL
6	42:00:00: SX:99:56:80	FR Lever Ass'y	F R 組立	TC-800GL
7	42:00:00: SX:99:56:90	FWD Pulley Ass'y	FWDプーリーレバー組立	TC-800GL
8	42:00:00: SX:99:57:00	Reel Tablet Assembly Right	リール台受板 B 線組立	TC-800GL
9	42:00:00: SX:99:57:10	Pause Connecting Lever Ass'y	ポーズ連動レバー組立	TC-800GL
10	42:00:00: SX:99:57:20	Flywheel Ass'y	フライホイール組立	TC-800GL
11	42:00:00: SX:99:57:30	Flywheel Bearing Plate Ass'y	フライホイール受板組立	TC-800GL
12	42:00:00: SX:99:57:40	Record Lever Ass'y	RECレバー組立	TC-800GL
13	42:00:00: SX:99:57:50	Record Connecting Lever Ass'y	REC連動レバー	TC-800GL
14	42:00:00: SX:99:57:60	Recording Plate Ass'y	REC作動板組立	TC-800GL
15				
16	42:00:00: SX:99:57:80	Index Counter Ass'y	テープカウンター SMP390-46	TC-800GL
17	42:00:00: SX:99:57:90	Counter Fixing Plate	カウンター取付板	TC-800GL
18	42:00:00: SX:99:58:00	Switch Plate	S W 受座	TC-800GL
19	42:00:00: SX:99:58:10	Switch Reed Type	リードスイッチ	TC-800GL
20	42:00:00: SX:99:58:20	Switch Chrome Senson	クローム切換SW取付板	TC-800GL
21	42:00:00: SX:99:58:40	Push Button Ass'y	押ボタンブロック組立	TC-800GL
22	42:00:00: SX:99:58:50	Cassette Holder	カセットケース組立	TC-800GL
23	42:00:00: SX:99:58:60	Brake Lever Connecting Metal	ブレーキ作動レバー	TC-800GL
24	42:00:00: SX:99:58:70	Limit Arm	停止レバー	TC-800GL
25	42:00:00: SX:99:58:80	Cassette Case Shaft	カセットケース軸	TC-800GL
26	42:00:00: SX:99:58:90	Pause Lever B	ポーズレバー B	TC-800GL
27	42:00:00: SX:99:59:00	Brake Lever	ブレーキレバー	TC-800GL
28	42:00:00: SX:99:59:10	Un Recording Plate	録音防止板	TC-800GL
29	42:00:00: SX:99:59:20	Case Fook Lever	ケースフックレバー	TC-800GL
30	42:00:00: SX:99:59:30	Head Base Metal	ヘッドベース作動板	TC-800GL
31	42:00:00: SX:99:59:40	F.F Lever	F・Fレバー	TC-800GL
32	42:00:00: SX:99:59:50	Rew Lever	REWレバー	TC-800GL
33	42:00:00: SX:99:59:60	Hook Lever	フックレバー	TC-800GL
34	42:00:00: SX:99:59:70	Un Look Lever	解除レバー	TC-800GL
35	42:00:00: SX:99:59:80	Strut Flywheel	フライホイール受柱 B	TC-800GL
36	42:00:00: SX:99:59:90	Head Base Lock Spring	ヘッドベース押エバネ B	TC-800GL
37	42:00:00: SX:99:60:00	Reel Tablet Ass'y Left	リール受台組立	TC-800GL
38	42:00:00: SX:99:60:10	Cap Reel Tablet	リール軸キャップ	TC-800GL
39	42:00:00: SX:99:60:20	Belt Reel	角ベルト 1.2φ×56φ	TC-800GL
40	42:00:00: SX:99:60:30	Pulley	モータープーリー	TC-800GL
41	42:00:00: SX:99:60:40	Belt Capstar	平ベルト φ1138×6×0.4	TC-800GL
42	42:00:00: SX:99:60:50	Record Lever Lock Plate	RECレバー保持板	TC-800GL
43	42:00:00: SX:99:60:60	REC/PB Switch Actuator	録再 SW 押し板	TC-800GL
44	42:00:00: SX:99:60:70	Belt Index Counter	丸ベルト 1φ×64φ	TC-800GL
45	42:00:00: SX:99:60:80	Contral Plate Holder	コントロール台受板	TC-800GL
46	42:00:00: SX:99:60:90	Play Button Lock Lever B	プレイロックレバー B	TC-800GL
47	41:00:00: SX:99:61:00	Head Record/Play Back	録再生ヘッド HN424823	TC-800GL
48	42:00:00: SX:99:61:10	Head Erace	消去ヘッド HF213850	TC-800GL
49	42:00:00: SX:99:61:20	Motor Ass'y	モーター-MYE-15DV	TC-800GL

